

User Manual

ALTIMIUM

AMP2B Mini Digital Amplifier



All Rights Reserved

Version: AMP2B_2016V1.1

Preface

Read this user manual carefully before using this product. Pictures shown in this manual is for reference only, different model and specifications are subject to real product.

This manual is only for operation instruction only, not for any maintenance usage. The functions described in this version are updated till December 2016. Any changes of functions and parameters since then will be informed separately. Please refer to the dealers for the latest details.

All product function is valid till 2016-12-2.

Trademarks

Product model and its logo are trademarks. Any other trademarks mentioned in this manual are acknowledged as the properties of the trademark owner. No part of this publication may be copied or reproduced without our prior written consent.

FCC Statement

This equipment generates, uses and can radiate radio frequency energy and, if not installed and used in accordance with the instructions, may cause harmful interference to radio communications. It has been tested and found to comply with the limits for a Class B digital device, pursuant to part 15 of the FCC Rules. These limits are designed to provide reasonable protection against harmful interference in a commercial installation.

Operation of this equipment in a residential area is likely to cause interference, in which case the user at their own expense will be required to take whatever measures may be necessary to correct the interference

Any changes or modifications not expressly approved by the manufacture would void the user's authority to operate the equipment.



SAFETY PRECAUTIONS

To insure the best from the product, please read all instructions carefully before using the device. Save this manual for further reference.

- Unpack the equipment carefully and save the original box and packing material for possible future shipment
- Follow basic safety precautions to reduce the risk of fire, electrical shock and injury to persons.
- Do not dismantle the housing or modify the module. It may result in electrical shock or burn.
- Using supplies or parts not meeting the products' specifications may cause damage, deterioration or malfunction.
- Refer all servicing to qualified service personnel.
- To prevent fire or shock hazard, do not expose the unit to rain, moisture or install this product near water.
- Do not put any heavy items on the extension cable in case of extrusion.
- Do not remove the housing of the device as opening or removing housing may expose you to dangerous voltage or other hazards.
- Install the device in a place with fine ventilation to avoid damage caused by overheat.
- Keep the module away from liquids.
- Spillage into the housing may result in fire, electrical shock, or equipment damage. If an object or liquid falls or spills on to the housing, unplug the module immediately.
- Do not twist or pull by force ends of the optical cable. It can cause malfunction.
- Do not use liquid or aerosol cleaners to clean this unit. Always unplug the power to the device before cleaning.
- Unplug the power cord when left unused for a long period of time.
- Information on disposal for scrapped devices: do not burn or mix with general household waste, please treat them as normal electrical wastes.

Table of Contents

1.Introduction	1
1.1.Introduction to AMP2B	1
1.2.Features	1
1.3.Package List.....	1
2.System Connection Introduction	3
2.1.Audio Output	3
2.1.1.Default output: 2x20Watt@4Ohm	3
2.1.2.Bridge connection: 1x40Watt@8Ohm	3
2.1.3.Dual-mono Output.....	3
2.2.Microphone input.....	4
2.2.1.48V phantom power input	4
2.2.2.MIC input	4
2.2.3.LINE input.....	4
3.Operation of the Control Panel and the IR Remote	6
3.1.Operation of the Control Panel	6
3.1.1.Audio switching	6
3.1.2.Volume/EQ controlling	6
3.2.Usage of the IR Remote	7
4.System Diagram	8
5.Communication Protocol and Command Codes	8
6.Specification.....	11
7.Panel Drawing	12
8.Troubleshooting & Maintenance	13
9.After-sales Service.....	14

1. Introduction

1.1. Introduction to AMP2B

AMP2B is a compact-size digital amplifier (Class-D) with 3 inputs (2 line in and 1 balanced MIC). It is integrated with powerful functions, including bridge connection, dual-mono, EQ control, microphone mixer etc.

It has a good application in different places, including classroom, small meeting room, lecture hall, bar, pub etc.

1.2. Features

- 2x20Watt@4Ohm as the default amplifier output.
- Bridge connection function. User can switch the AMP2B to be 1x40Watt@8Ohm by bridge connection.
- Two stereo audio inputs, switchable by button, IR remote & RS232.
- Volume/Bass/Treble controllable by buttons IR remote & RS232.
- MIC port can support balance/unbalance signal, suppress the external noise effectively.
- Line audio output at 3.5mm jack, with volume controllable.
- Dual-mono function. User can sum up the stereo audio to two times mono audio.
- MIC mixer function. The microphone will be mixed to the line audio output, and be controlled separately.
- MIC input supports 48V phantom power, dynamic MIC and wireless MIC.
- Auto noise gate. It keeps detecting the audio and MIC input, will mute the output when there is no input.
- Ultra low inrush current, no need for power sequencing. This allows multiple AMP2B to be powered on simultaneously without overloading power circuits.
- Convection cooler, fan is not needed.
- Antistatic case design: providing good protection for long-term and stable performance.

1.3. Package List

- 1 x AMP2B (The mounting ears and AMP2B are as a whole.)
- 2 x Pluggable Terminal Blocks
- 1 x RS232 Cable
- 1 x Power Adapter
- 1 x Power Cord

Mini Digital Amplifier

- 4 x Plastic Cushions
- 1 x User Manual

Notes:

- The IR remote and its battery are offered for charge separately.
- The IR receiver is also offered for charge.
- Please confirm if the product and the accessories are all included, if not, please contact with the dealers.

Mini Digital Amplifier

2. System Connection Introduction

2.1. Audio Output

2.1.1. Default output: 2x20Watt@40hm

The default output of amplifier is 2x20Watt@40hm, so user can connect the amplifier output in the regular way. As the picture below:

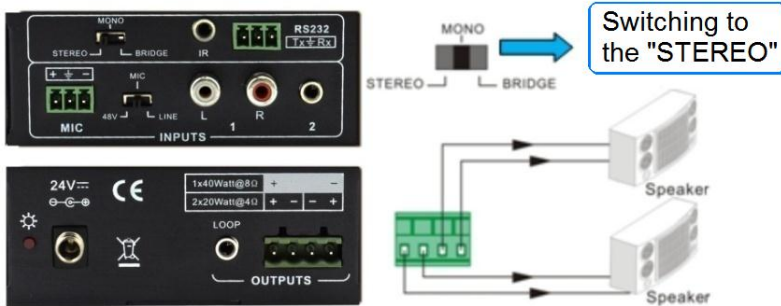

2.1.2. Bridge connection: 1x40Watt@80hm

AMP2B has the bridge connection, to double the output power at 1x40Watt@80hm. It will sum up the input left channel and input right channel to be mono output, and the power is up to 40Watt.

The bridge connection is:

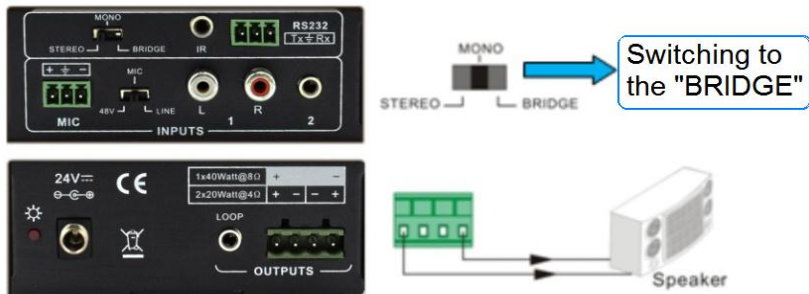

2.1.3. Dual-mono Output

AMP2B also has the function of double-mono output. It can sum up the left and right channel, to be the mono audio output. In this way, the both of the outputs are showing the same mono audio. The connection is:

Mini Digital Amplifier

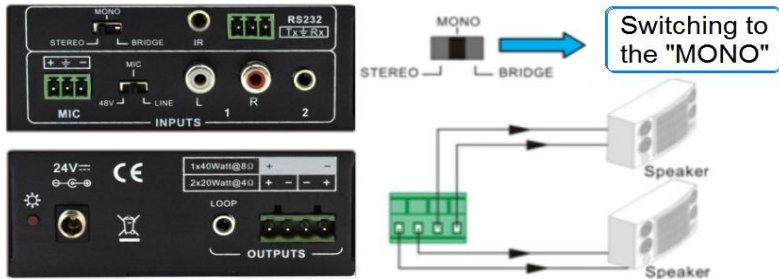

2.2. Microphone input

The microphone input of AMP2B has three modes, and different modes use different connections, as the picture below:



2.2.1. 48V phantom power input

When the switch turns to “48V”, the MIC input will provide a 48V phantom power. This is usually used for power supply for condenser microphone, Connection is: “+” connects to positive, “-” connects to negative and “⊥” to ground.

Note: In this mode, only condenser microphone can be connected with.

2.2.2. MIC input

When the switch turns to “MIC”, the microphone input is used for connecting with dynamic microphone. There are two different connections:

1) Unbalanced connection:

“⊥” connects to ground, and “-” connects to signal.

“⊥” connects to ground, and “+” connects to signal.

2) Balanced connection: “+” connects to positive, “-” connects to negative and “⊥” connects to ground.

2.2.3. LINE input

When the switch turns to “LINE”, the microphone input is used for connecting with normal audio or wireless microphone output. There are two different connections:

1) Unbalanced connection:

“⊥” connects to ground, and “-” connects to signal.

“⊥” connects to ground, and “+” connects to signal.

Mini Digital Amplifier

- 2) Balanced connection: "+" connects to positive, "-" connects to negative and "⊥" connects to ground.

3. Operation of the Control Panel and the IR Remote

3.1. Operation of the Control Panel

The buttons provides the control of volume/EQ control and switching. The following content introduces audio switching and EQ control in detail.

3.1.1. Audio switching

There are two switchable stereo audio inputs, one 2xRCA input, and one 3.5mm jack input, switchable through the buttons as below:



3.1.2. Volume/EQ controlling

The line volume and MIC volume can be controlled by the buttons.

The MIC Volume/LINE volume/LINE bass/LINE treble will be selected by the buttons, and controlled up/down/mute by the function buttons. Please check the picture below:

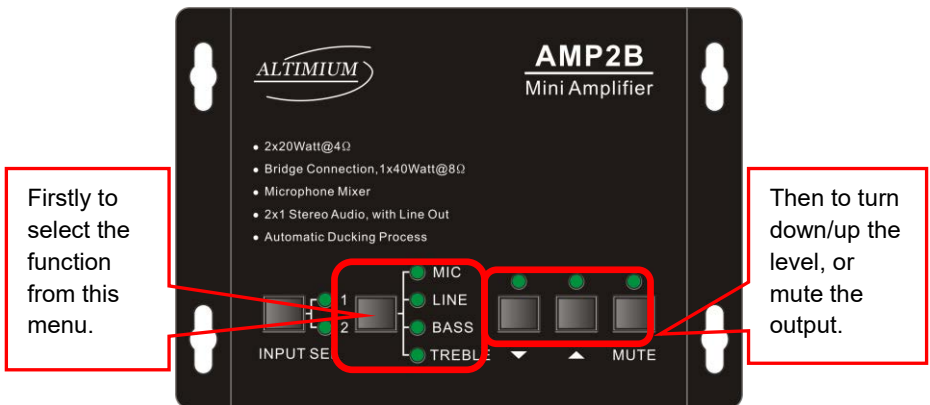

For example, to turn up the line volume, you should select the "LINE" first, and then press the button "▲".

3.2. Usage of the IR Remote



Audio Inputs
1: RCA dual-mono audio inputs
2: 3.5mm jack

Audio Controlling Modes
MIC: turn up/down the microphone volume.
LINE: turn up/down the line volume.
BASS: bass tuning
TREBLE: treble of line volume.

Use to transmit the infrared signal send by the IR remote.

Mute Mode:
MIC: Mute the microphone volume.
LINE: Mute the line volume.
SPEAKER: Unmute

IR receiver head, works in conjunction with the IR remote. Please point the IR remote at the IR receiver when use, to avoid getting out of control as there is no signal detected.

3.5mm jack, insert it into the specialized socket (3.5mm) to connect the IR receiver with the amplifier

Notice: The IR remote, the IR receiver, and the battery of the IR remote are all offered for charge.

4. System Diagram

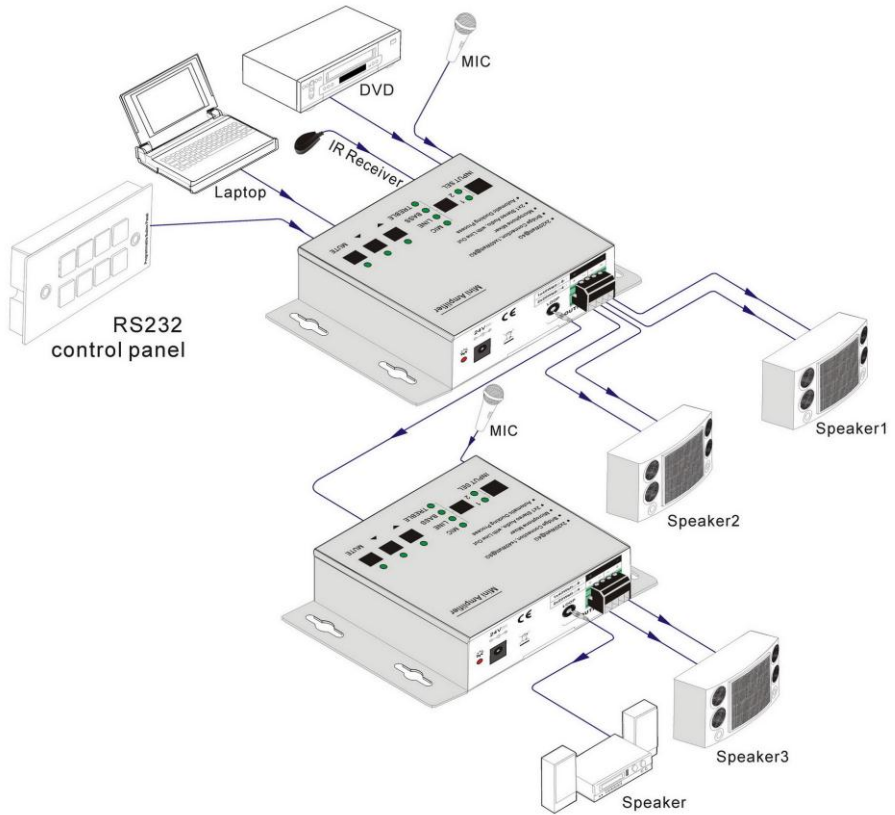

5. Communication Protocol and Command Codes

Communication Protocol: RS232 Communication Protocol

Baud rate: 9600 Data bit: 8 Stop bit: 1 Parity bit: none

Command	Function Description	Feedback Code
1A1.	Switching the audio to input 1	A: 1 -> 1
2A1.	Switching the audio to input 2	A: 2 -> 1
0A0.	Mute Audio of MIC and Line out	Mute
1A0.	Mute audio of MIC	Mute MIC
2A0.	Mute audio of line out	Mute LIN
0A1.	Unmute Audio	Unmute
3A0.	Switch on Noise Gate	Gate On
4A0.	Switch off Noise Gate	Gate Off
600%	Checking the working status	A: 1 -> 1 Volume: 30 Bass: 00 Treble: 00
601%	MIC volume up	Volume of MIC: 51
602%	MIC volume down	Volume of MIC: 51
603%	Line volume up	Volume of LINE: 51
604%	Line volume down	Volume of LINE: 51
605%	Bass level up	Bass of LINE: 04
606%	Bass level down	Bass of LINE: 04
607%	Treble level up	Treble of LINE: 04
608%	Treble level down	Treble of LINE: 04
609%	Initialization, back to the default setting	Init OK
5[x][x]%	Preset MIC volume, [xx] arranges from [00] to [60]. 61 degrees in total.	Volume of MIC: 50
7[x][x]%	Preset line volume, [xx] arranges from [00] to [60]. 61 degrees in total.	Volume of LINE: 50
8[x][x]%	Preset the bass level, [xx] arranges from [00] to [08]. 9 degrees in total.	Bass of LINE: 04
9[x][x]%	Preset the treble level, [xx] arranges from [00] to [08]. 9 degrees in total.	Treble of LINE: 04

Notice:

Mini Digital Amplifier

- 1: The letter inside bracket [] is the variable code, which is changeable.
- 2: The bracket [] is not included to the RS232 commands.
- 3: Any dot "." after the letters is part of the commands.

Example 1:

Switching the input 2 to the line out, RS232 command is: [2A1.]

Example 2:

Turning up the volume of line audio, RS232 command is: [603%]

Example 3:

Preset the MIC volume to "21" degree, RS232 command is: [521%]

Example 4:

Checking the working status of AMP2B, RS232 command is: [600%]

6. Specification

Audio Input		Audio Output	
Input	2 stereo audio, 1 MIC	Output	1 amplifier, 1 stereo audio
Input Connector	2 RCA 1 3.5mm jack 1 pluggable terminal block (3P,3.81mm),	Output Connector	1 3.5mm jack 1 pluggable terminal block (4P, 5.08mm)
Input Impedance	>10K Ω	Output Impedance	50 Ω /stereo, 4~8 Ω /Amplifier
Audio General			
Frequency Response	20Hz ~ 20KHz	CMRR	>70dB@20Hz~20KHz
SNR	80dB at maximum output	Bandwidth	20Hz ~ 25KHz
Stereo Channel Separation	>75dB@20Hz to 20KHz	THD + Noise	1%@1KHz, 0.3%@20KHz at nominal level
Voltage Gain	32dB	Power Output	2x20 Watts (4 Ohms)
Control Function			
RS232 Control	3-hole phoenix connector	Panel Control	Optional button control
IR Remote	Optional IR remote		

7. Panel Drawing

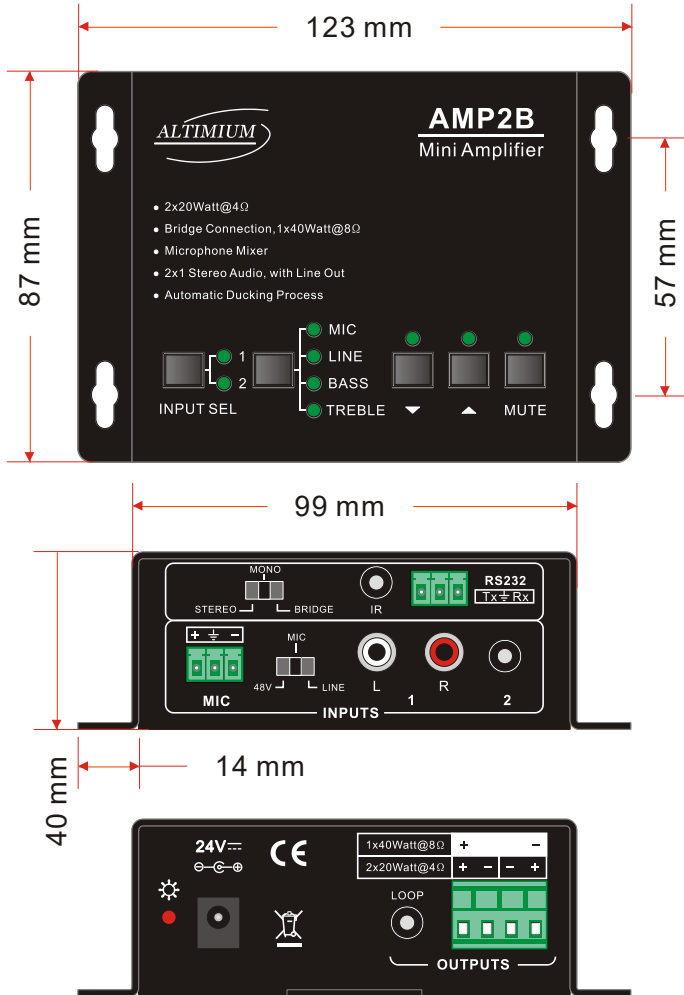

8. Troubleshooting & Maintenance

1) When there is no output audio:

- Check if there is any signal at the input.
- Check if there is any signal at the output.

We can check these by using an oscilloscope or a multimeter. If there is no signal input/output, maybe the input/output cables broken or the connectors loosen, please change for another cable.

- Check if the output port number is the same with the controlled one.
 - If not the problem mentioned above, probably there is something broken inside the unit, please send it to the dealer for repairing.
- 2) If the **POWER** indicator doesn't work or no respond to any operation, please make sure the power cord connection is good.
- 3) If the output sound is interfered, please make sure the system is grounded well.
- 4) If the static becomes stronger when connecting the audio connectors, it probably due to bad grounding, please check the grounding and make sure it connected well, otherwise it would damage the converter.
- 5) If the AMP2B amplifier cannot be controlled by the keys on the front panel, RS232 port or IR remote, the unit may has already been broken. Please send it to the dealer for repairing.

9. After-sales Service

If there appear some problems when running the device, please check and deal with the problems referring to this user manual.

1) Product Limited Warranty: We warrant that our products will be free from defects in materials and workmanship for **three years**, which starts from the first day you buy this product (The purchase invoice shall prevail).

Proof of purchase in the form of a bill of sale or receipted invoice which is evidence that the unit is within the Warranty period must be presented to obtain warranty service.

2) What the warranty does not cover (servicing available for a fee):

- Warranty expiration.
- Factory applied serial number has been altered or removed from the product.
- Damage, deterioration or malfunction caused by:
 - Normal wear and tear
 - Use of supplies or parts not meeting our specifications
 - No certificate or invoice as the proof of warranty.
 - The product model showed on the warranty card does not match with the model of the product for repairing or had been altered.
 - Damage caused by force majeure.
 - Servicing not authorized
 - Any other causes which does not relate to a product defect
- Delivery, installation or labor charges for installation or setup of the product

3) Technical Support: Email to our after-sales department or make a call, please inform us the following information about your cases.

- Product version and name.
- Detailed failure situations.
- The formation of the cases.

Remarks: For any questions or problems, please try to get help from your local distributor.



ALTIMIUM

587 Avenue Blaise Pascal

77550 MOISSY-CRAMAYEL

Tél : 01.64.13.31.00

Fax: 01.60.29.62.70

Mail: contact@tesca-audio.com

Web: www.altimum.com